

# SERIES 805 TRIPLE-START ACME THREAD Mighty Mouse Connectors and Cables



## Glass-Sealed Hermetic Receptacle with PC Tails or Solder Cup Contacts



### Series 805 Hermetic Receptacles

Glass-to-metal seal hermetic connectors feature solder cup contacts for direct wire attachment or PC tails for PC board termination. Contacts are gold plated, nickel alloy pin contacts and copper alloy socket contacts. Shell styles include square flange, solder mount, jam-nut, and weld mount. Connectors are 100% tested to meet  $1 \times 10^{-7}$  ccHe/sec at 1 atm helium leak rate. Contacts are non-removable, back potted, and parylene compatible. Consult factory for additional arrangements.

How To Order	
<b>Sample Part Number</b>	805-006 -02 Z1 8-7 P A
<b>Series</b>	805-006 = Hermetic Receptacle with Solder Cups
<b>Shell Style (See Table I)</b>	-02 = Square Flange, Front or Rear Mount Receptacle -03 = Solder Mount Receptacle -07 = Jam-Nut, Rear Panel Mount Receptacle -13 = Weld Mount, Front Panel Mount Receptacle
<b>Material and Finish</b>	Z1 = Stainless Steel / Passivated ZB = Stainless Steel / Olive Drab Chromate over Cadmium ZC = Stainless Steel / Zinc Cobalt Alloy/Black Chromate ZL = Stainless Steel / Electrodeposited Nickel
<b>Shell Size - Insert Arrangement</b>	See page J-6*
<b>Contact Type</b>	P = Pin, Solder Cup S = Socket, Solder Cup C = Pin, P.C. Termination D = Socket, P.C. Termination
<b>Shell Key Positions (See Table II)</b>	A = Normal B = Pos. B C = Pos. C D = Pos. D E = Pos. F F = Pos. F

\*Power and signal contacts only. For shielded contact applications, see P/N 805-130

Table I: Shell Style	
-02 Square Flange	-07 Jam-Nut
-03 Solder Mount	-13 Weld Mount

DWV Rating	
Contact Sizes	Test Voltage
23	750 Vac
20 HD	1000 Vac
16, 12, 8	1800 Vac

Table II: Key Positions		
Position	A	B
A (Normal)	150°	210°
B	75°	210°
C	95°	230°
D	140°	275°
E	75°	275°
F	95°	210°

### NOTES

- This connector mates with all quick coupling high density plug connectors with same polarization and opposite contact gender 805-001, 805-002
- For additional insert arrangements consult factory
- Contacts are non removable and connector is back potted
- Hermeticity is less than  $1 \times 10^{-7}$  ccHe/second at one atmosphere
- See page J-11 for recommended panel cut-outs
- Material/Finish:
  - Shell, jam-nut: CRES / passivate or plate as required
  - Contacts, hermetic: alloy 52 / gold plate
  - Contacts, socket: copper alloy / gold plate
  - Seals: fluorosilicone / N.A.
  - Insulator, hermetic: fused glass / N.A.
  - Insulator, socket: rigid dielectric / N.A.

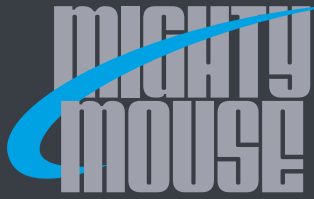

# SERIES 805 TRIPLE-START ACME THREAD Mighty Mouse Connectors and Cables



## Glass-Sealed Hermetic Receptacle with PC Tails or Solder Cup Contacts

### SQUARE FLANGE RECEPTACLE - SHELL STYLE 02

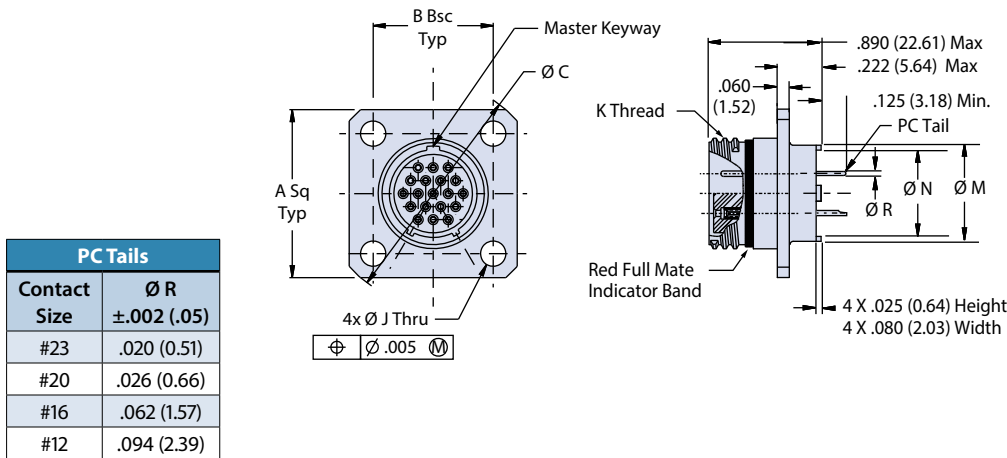

### SOLDER MOUNT RECEPTACLE - SHELL STYLE 03

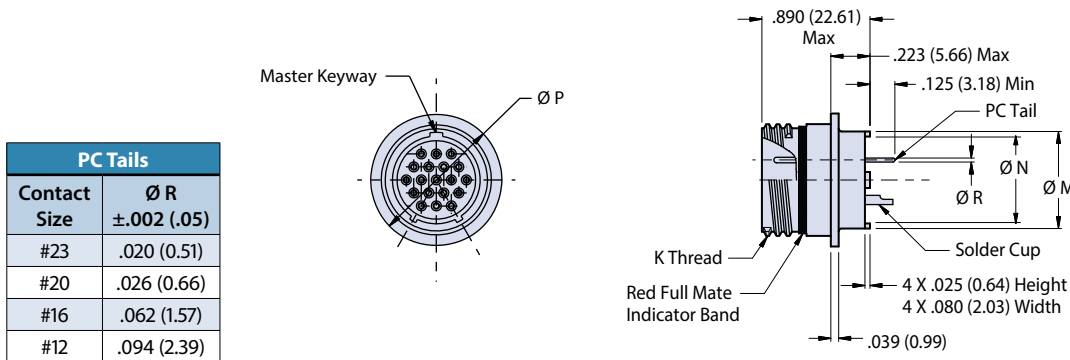

Dimensions											
Shell Size	A Sq	B Bsc	Ø C	J Holes	K Thread .1P-.3L-TS	Ø M	Ø N Min	Ø P	H BSC	Square Flange Cutout	
										J Holes	Ø P
8	.850 (21.59)	.660 (16.76)	1.150 (29.21)	.096 (2.44)	.5000	.330 (8.38)	.230 (5.84)	.625 (15.88)	.660 (16.76)	.096 (2.43)	.515 (13.08)
9	.913 (23.19)	.723 (18.36)	1.230 (31.24)		.5625	.432 (10.97)	.322 (8.18)	.688 (17.48)	.723 (18.36)		.578 (14.68)
10	.975 (24.76)	.785 (19.94)	1.330 (33.78)		.6250	.493 (12.52)	.386 (9.80)	.750 (19.05)	.785 (19.94)		.640 (16.26)
11	1.039 (26.39)	.848 (21.54)	1.410 (35.81)		.6875	.553 (14.05)	.442 (11.23)	.812 (20.62)	.848 (21.54)		.703 (17.86)
12	1.099 (27.91)	.909 (23.09)	1.500 (38.10)	.091 (2.31)	.7500	.620 (15.75)	.513 (13.03)	.875 (22.23)	.909 (23.09)	.091 (2.31)	.765 (19.43)
13	1.163 (29.54)	.973 (24.71)	1.590 (40.39)		.8125	.661 (16.79)	.554 (14.07)	.938 (23.83)	.973 (24.71)		.828 (21.03)
15	1.288 (32.72)	1.058 (26.87)	1.750 (44.45)		.9375	.703 (17.86)	.594 (15.09)	1.062 (26.97)	1.058 (26.87)		.953 (24.21)
18	1.475 (37.47)	1.255 (31.88)	2.000 (50.80)		.130 (3.30)	1.1250	.863 (21.92)	.750 (19.05)	1.250 (31.75)		1.255 (31.88)
19	1.537 (39.04)	1.327 (33.71)	2.094 (53.19)	.126 (3.20)	1.1875	.912 (23.16)	.805 (20.45)	1.312 (33.32)	1.327 (33.71)	.126 (3.20)	1.203 (3.56)
21	1.663 (42.24)	1.452 (36.88)	2.270 (57.66)		1.3125	1.017 (25.83)	.910 (23.11)	1.438 (36.53)	1.452 (36.88)		1.328 (33.73)
23	1.787 (45.39)	1.576 (40.03)	2.440 (61.98)		1.4375-	1.162 (29.51)	1.050 (26.67)	1.562 (39.67)	1.570 (39.88)		1.453 (36.91)

SERIES 805 TRIPLE-START ACME THREAD

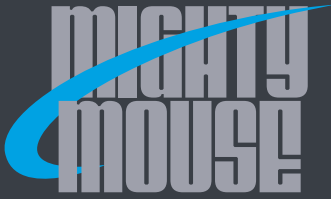

# SERIES 805 TRIPLE-START ACME THREAD Mighty Mouse Connectors and Cables



## Glass-Sealed Hermetic Receptacle with PC Tails or Solder Cup Contacts

### JAM-NUT MOUNT RECEPTACLE - SHELL STYLE 07

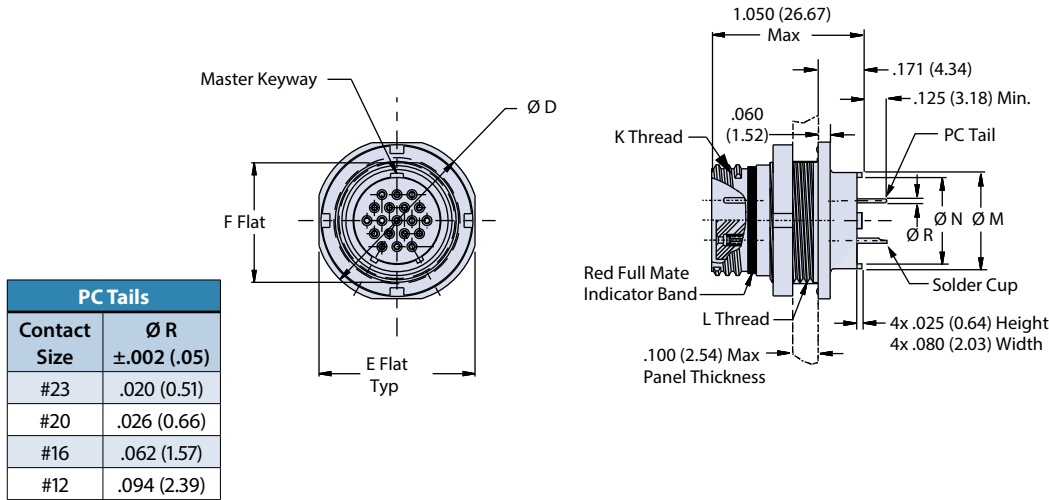

### WELD MOUNT RECEPTACLE - SHELL STYLE 13

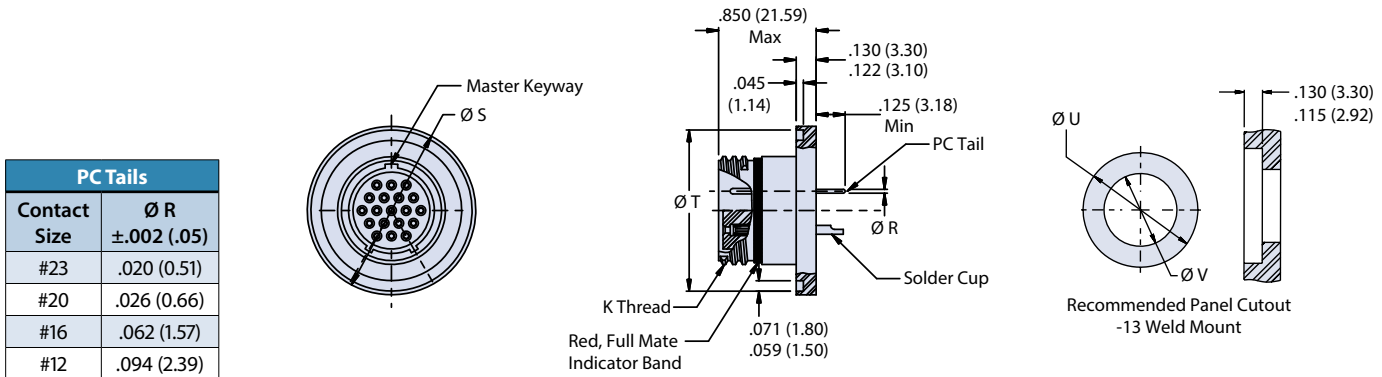

Dimensions												
Shell Size	Ø D	E Flat	F Flat	K Thread -1P-.3L- TS	L Thread -28 UN-2A	Ø M	Ø N Min	Ø S ±.002	Jam-Nut Cutout		Weld Mount Cutout	
									G Flat ±.002(.05)	Ø H +.005 (+.13) -.000 (-.00)	Ø U ±.003 (0.08)	Ø V Min
8	.760 (19.30)	.730 (18.54)	.535 (13.59)	.5000	.5625	.330 (8.38)	.230 (5.84)	.788 (20.02)	.543 (13.79)	.567 (14.40)	0.794 (20.17)	.350 (8.89)
9	.880 (22.35)	.850 (21.59)	.661 (16.79)	.5625	.6875	.432 (10.97)	.322 (8.18)	.912 (23.16)	.669 (16.99)	.693 (17.60)	0.918 (23.32)	.455 (11.56)
10	.880 (22.35)	.850 (21.59)	.661 (16.79)	.6250	.6875	.493 (12.52)	.386 (9.80)	.975 (24.76)	.669 (16.99)	.693 (17.60)	0.981 (24.92)	.520 (13.21)
11	.955 (24.26)	.925 (23.50)	.721 (18.31)	.6875	.7500	.553 (14.05)	.442 (11.23)	1.038 (26.37)	.729 (18.52)	.755 (19.18)	1.044 (26.52)	.575 (14.60)
12	1.060 (26.92)	1.035 (26.29)	.784 (19.91)	.7500	.8125	.620 (15.75)	.513 (13.03)	1.100 (27.94)	.792 (20.12)	.817 (20.75)	1.106 (28.09)	.650 (16.51)
13	1.120 (28.45)	1.090 (27.69)	.843 (21.41)	.8125	.8750	.661 (16.79)	.554 (14.07)	1.162 (29.51)	.849 (21.56)	.881 (22.38)	1.168 (29.67)	.685 (17.40)
15	1.203 (30.56)	1.173 (29.79)	.970 (24.64)	.9375	1.0000	.703 (17.86)	.594 (15.09)	1.288 (32.72)	.978 (24.84)	1.005 (25.53)	1.294 (32.87)	.730 (18.54)
18	1.389 (35.28)	1.359 (34.52)	1.147 (29.13)	1.1250	1.1875	.863 (21.92)	.750 (19.05)	1.475 (37.47)	1.155 (29.34)	1.193 (30.30)	1.481 (37.62)	.890 (22.61)
19	1.450 (36.83)	1.420 (36.07)	1.221 (31.01)	1.1875	1.2500	.912 (23.16)	.805 (20.45)	1.540 (39.12)	1.229 (31.22)	1.255 (31.88)	1.546 (39.27)	.940 (23.88)
21	1.58 (40.13)	1.550 (39.37)	1.35 (34.29)	1.3125	1.3750	1.017 (25.83)	.910 (23.11)	1.665 (42.29)	1.356 (34.44)	1.383 (35.13) 1.381 (35.08)	1.671 (42.44)	1.040 (26.42)
23	1.705 (43.31)	1.675 (42.55)	1.470 (37.34)	1.4375	1.5000	1.162 (29.51)	1.050 (26.67)	1.795 (45.59)	1.478 (37.54)	1.505 (38.23)	1.801 (45.75)	1.190 (30.23)

SERIES 805 TRIPLE-START ACME THREAD